

OPEX Model 50 Rapid Extraction Desk

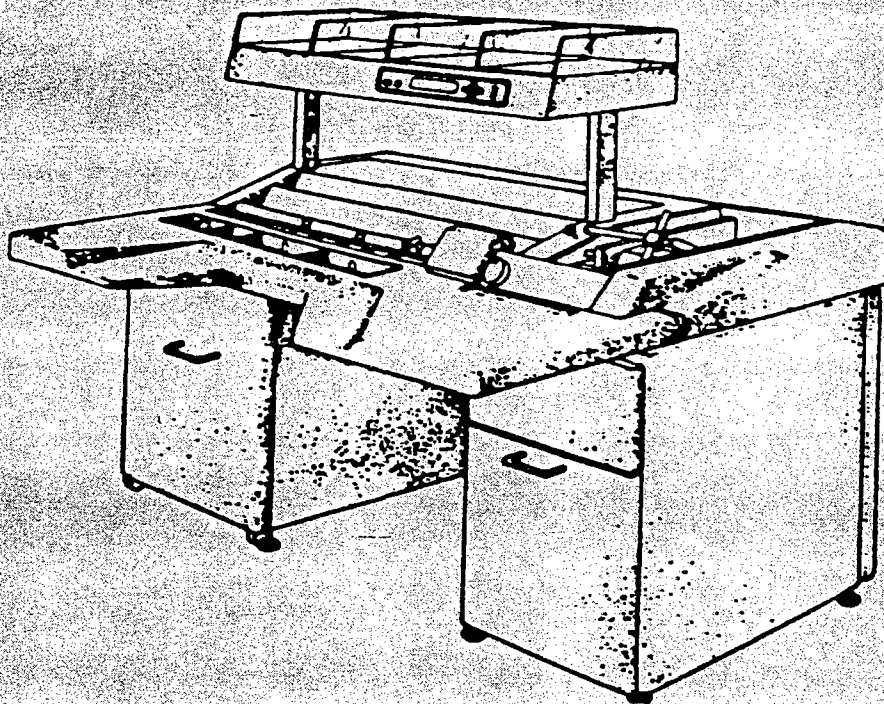

Operator Manual

OPEX[®]
CORPORATION

A MESSAGE FROM OPEX CORPORATION



*Al Stevens, President
OPEX Corporation*

Thank you for choosing OPEX equipment to manage your mail extraction needs. For more than twenty years, OPEX Corporation has been the leader in mailroom automation technology.

It's easy to become familiar with the *Model 50 Rapid Extraction Desk* because this workstation is user-friendly. This is no accident. OPEX designed the Model 50 RED with features to make your job easier while at the same time making you more productive.

Notice that the work area is well-lighted. The graphics and data are easy to read. The envelope is positioned so that the contents are easily accessible. The special ergonomic chair is well designed to keep you comfortable as you work.

The Model 50 RED represents the finest mail extraction equipment your company can buy. Features such as OPEX's patented "Content Activation"—an electronic scanning device which assures that each envelope is totally empty before it goes into the trash receptacle—are not available from anyone else in the industry. The OPEX Networking Solution™ option makes it possible to modify jobs and machine settings without disturbing the operator.

Over the years, OPEX Corporation has developed an unparalleled reputation for quick, comprehensive, accurate service. We realize how important it is for you to maintain uptime, so we've made it our goal to answer service calls within 4 hours. Just as important, and maybe even more so, is the speed with which a problem can be solved. 20 minutes (on average) is all the time necessary for an OPEX technician to complete a repair on a Model 50.

Welcome to the OPEX family! We wish you much success in your mail operation!

Sincerely yours,
OPEX CORPORATION

Albert F. Stevens
President

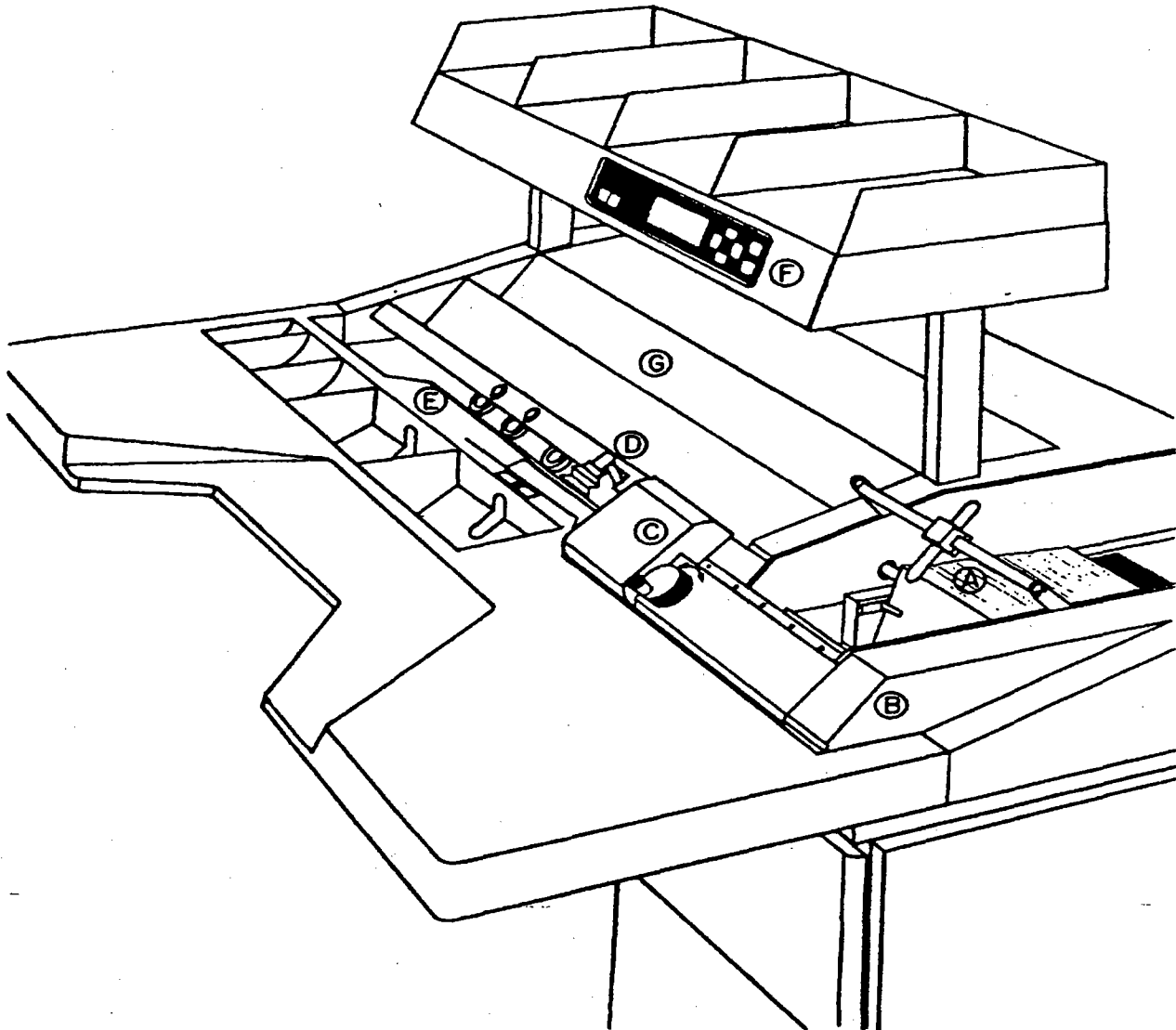

- A. FEED TRAY
- B. SIDE CUTTER
- C. TOP CUTTER
- D. EXTRACT POSITION
- E. CANDLING / ENVELOPE RETRIEVAL POSITION
- F. PERFORMANCE CONTROL CENTER
- G. SAW TOOTH CHECK / DOCUMENT SORTER

Illustration A. Feed Tray and Cutter Areas

Model 50 RED Operators, Please Note. . .

The OPEX Model 50 RED is designed to allow you to increase your productivity while at the same time reducing much of the physical stress normally associated with your job. In developing your Rapid Extraction Desk, OPEX engineers worked to make you more comfortable by:

- Angling the work surface
- Placing the Performance Control Center and top shelf in such a way that you can easily see and access important information
- Providing additional knee clearance to allow more freedom of movement
- Lighting the desk and extraction area
- Adding many other features to make your task easier

However, as in any occupation which requires you to perform the same motion repeatedly during the course of your shift, you must pay attention to *how* you perform your task. Always use proper operating procedures when working at your Desk. Follow directions for using and adjusting your chair or any other OPEX accessory. *Using improper procedure can result in a potentially serious injury.* To reduce possible risks, we strongly urge you to follow the 6 suggestions listed below:

1. Maintain an upright body posture. Avoid the temptation to slump in your chair. The torso to thigh angle, as shown in the illustration below, should never be less than 90 degrees.

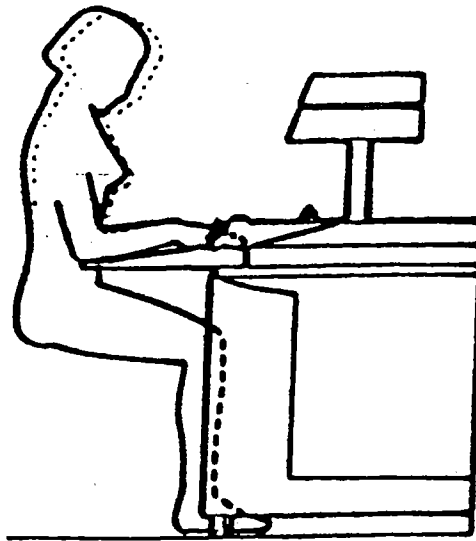

Illustration B. Correct Posture

2. Adjust the seat position on your chair so that your elbow, when held at a 90 degree angle at your side, is approximately 1 1/2 inches below the top of the Model 50 work surface. We recommend a specially designed OPEX ergonomic desk chair be used to ensure proper posture and seat position. Use the OPEX chair as described in the Accessories Operation portion of this manual.

3. Occasionally change the angle of your posture.
4. If possible, avoid operating the machine for longer than an 8 hour shift.
5. If you are under 5' in height, you might wish to place your feet on a footrest to provide greater comfort while operating the machine.
6. If you are over 6' in height, you will need to adjust the leveling feet on the machine to provide greater extension. If this still does not prove satisfactory, small blocks may be placed under the feet to raise the workstation an additional 1 to 2 inches.

While no suggestions can provide a 100% guarantee against work-related injuries, utilizing the 6 recommendations listed above can increase your comfort and safety while operating the OPEX Model 50 RED.

The Model 50 workstation was designed with you in mind. If the equipment is operated correctly you should find your work experience enjoyable.

OPEX Model 50 RED Starting and Operating Instructions. . .

Loading The Model 50

Loading the mail on your Rapid Extraction Desk is the first step. As a rule, your mail will probably consist of one-size envelopes, either short (No. 6), long (No. 10), or some consistent size in between. Some jobs consist of intermixed envelopes of varying sizes. This is called 'White Mail.'

Unless your Sales Representative or Service Technician directs otherwise, use the following procedure to prepare envelopes for opening and extraction:

1. Align the envelopes so that they are all facing in the same direction, right-side up.
2. Hand jog the envelopes on a hard surface so that their contents shift to the bottom of the envelope, away from the top cutter. This prevents a check or document from being accidentally sliced in the top cutter as the envelope is opened.
3. With the front of the envelopes facing you, rotate them 1/4 turn counterclockwise so that the edge opposite the stamped end is on the hard surface. Jog the envelopes again to shift the contents to the left (away from the side cutter). See illustration below:

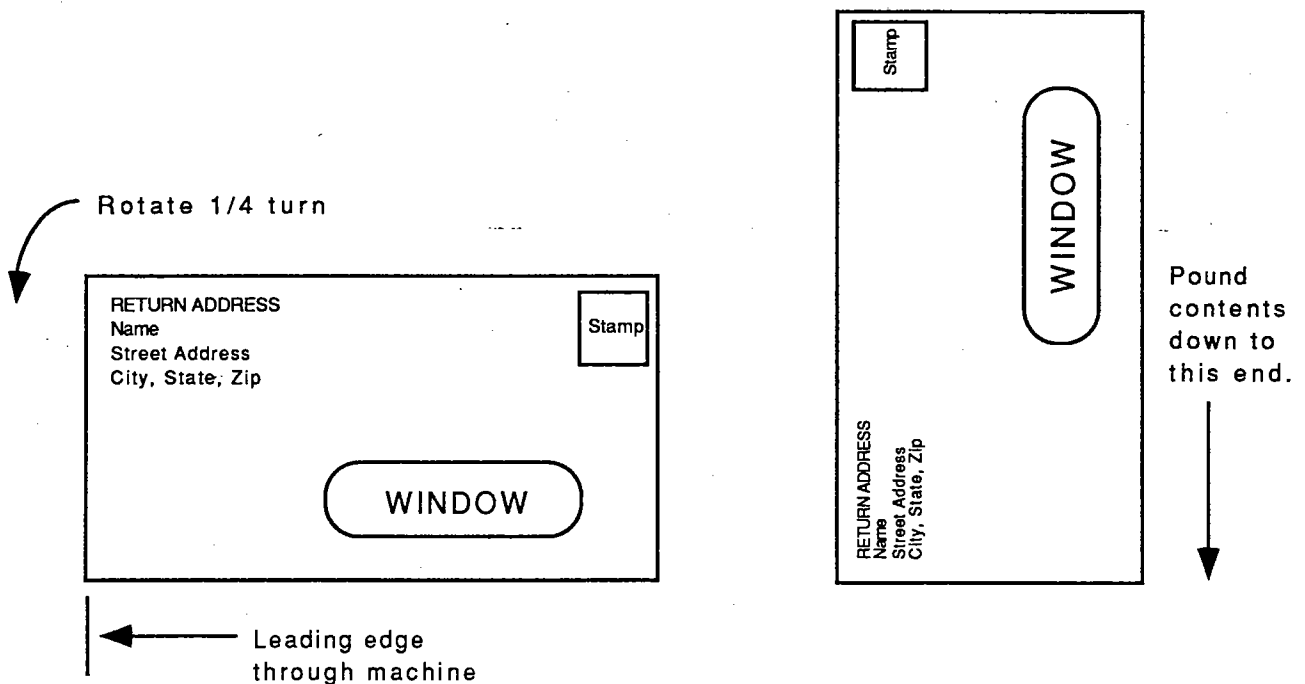

Illustration C. Envelope Contents and Position

4. Place the mail pusher block at the rear of the feed tray.
5. Loosen the guide bar knob. Move the guide bar far enough to the left to allow the mail to fit between the guide bar and the right wall of the feed area.
6. Load the mail, a handful at a time, into the rear of the feed area (see illustration D). Allow the mail to fall back against the mail pusher so that it lays back at the same angle as the front of the pusher.
7. Slide the guide bar to the right until it is touching the mail.
8. Move the guide bar back to the left about 1/8 of an inch, making sure that the envelopes remain behind the switch on the guide bar (see illustration D). Tighten the guide bar knob.
9. Slide the mail pusher forward just enough to bring the mail to the front of the feed area. Be sure to maintain a loose, angled arrangement of the mail.
10. Adjust the stripper bar(s): If the envelopes are long, move the stripper bar in towards the guide bar edge of the envelope; if the mail is shorter, position the guide bar in the middle of the mail.
11. Move the stripper tab down so that no more than 1/2 inch is touching the top of the leading envelope—this keeps the machine pick-up head from picking up more than one envelope at a time.

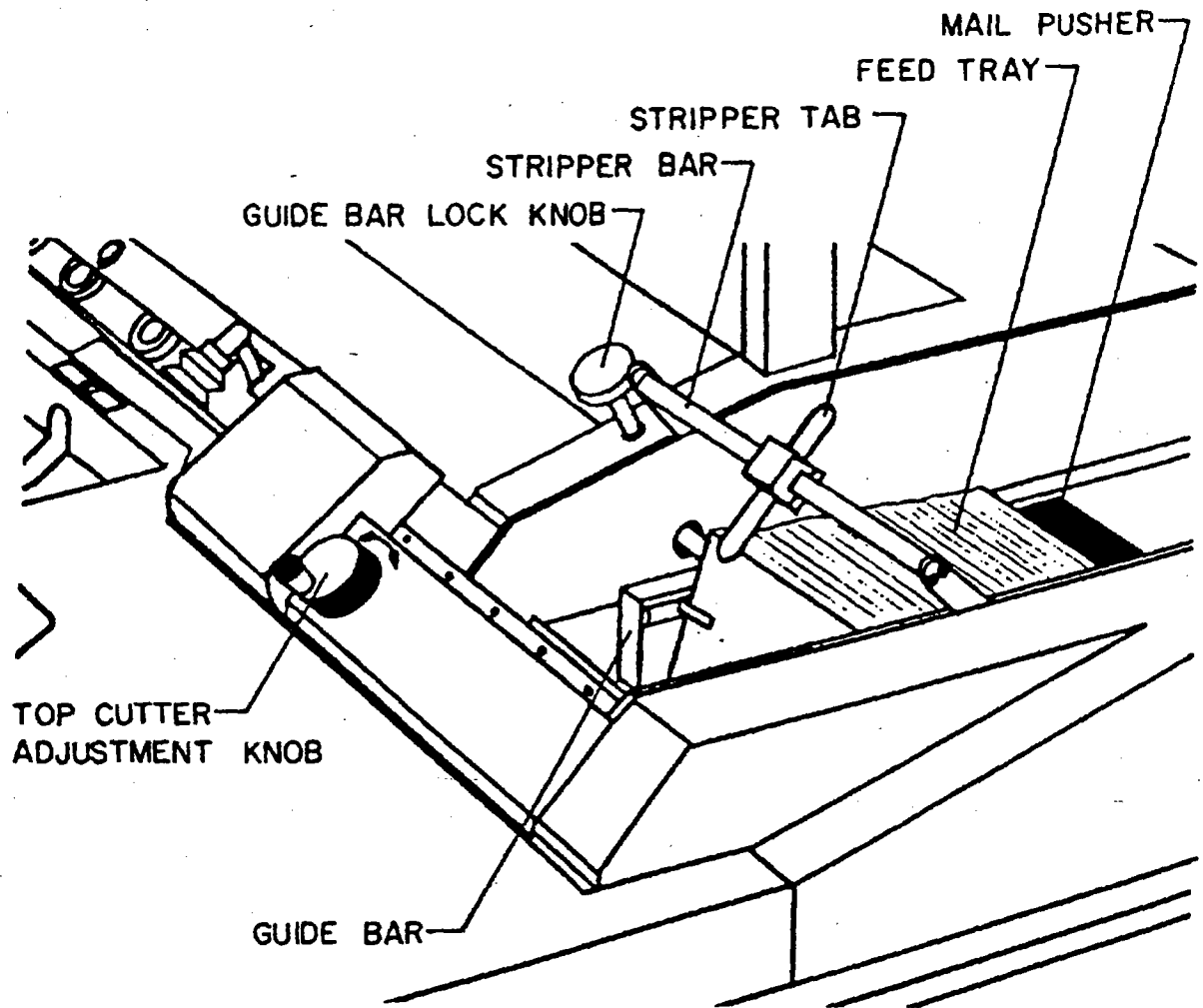
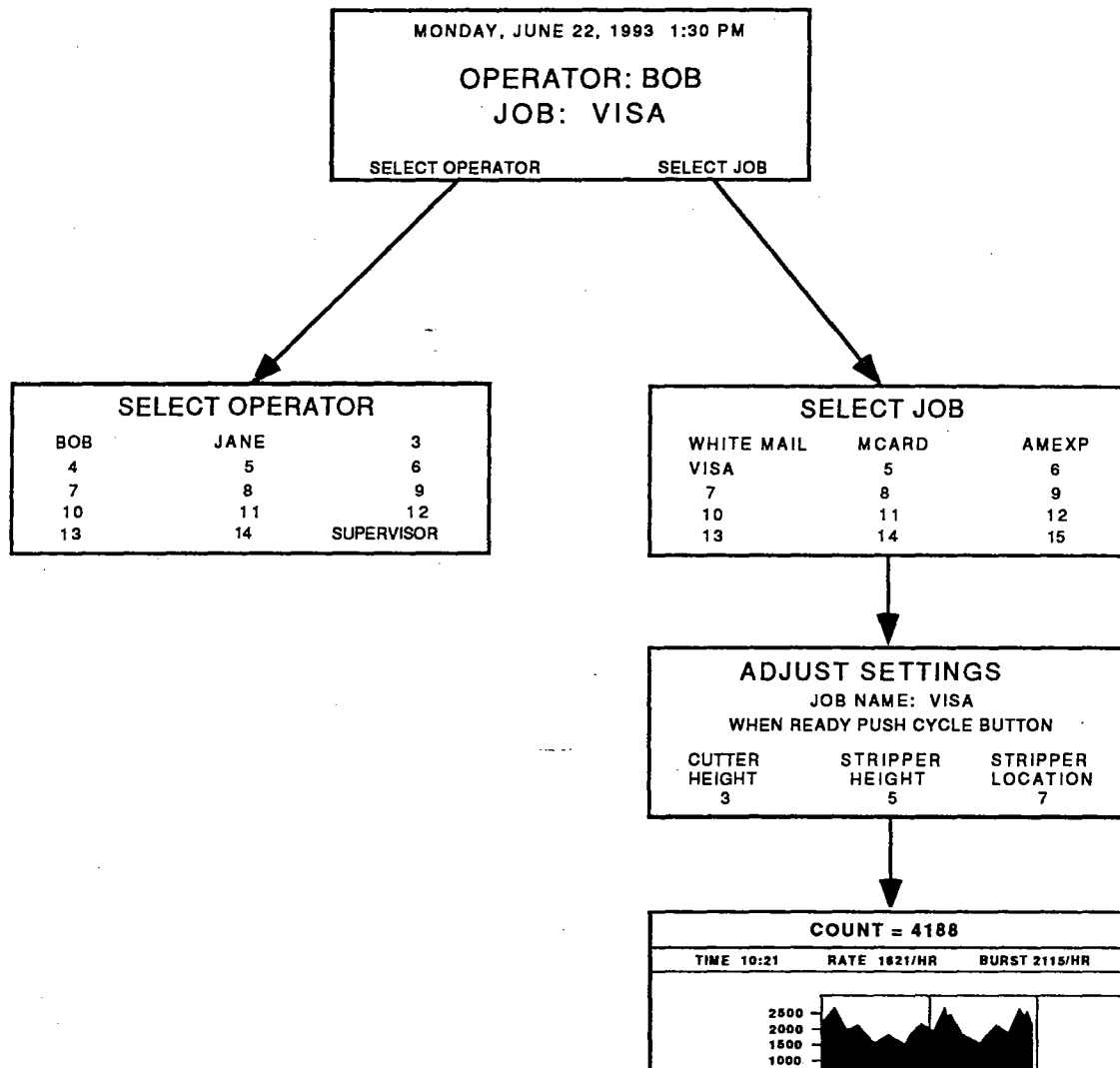

Illustration D. Feed Area

PERFORMANCE CONTROL CENTER OPERATOR SCREENS

When reading the descriptions of the PCC operator screens on the following pages, it may be difficult to remember where you are in the job or operator process. The chart below will help you to locate a particular screen and to see how it fits into the operator process. After you find the screen on the chart, refer to the detailed screen descriptions on pages 9 through 15.



BASIC OPERATION WITH PERFORMANCE CONTROL CENTER OPTION

Once you've loaded the mail into the Model 50 RED, turn the machine on. This next section of your manual assumes you are using the OPEX Performance Control Center (PCC). If your machine is not equipped with a PCC, please refer to page 16 of this manual.

Before continuing, take a moment to familiarize yourself with the PCC and the basic machine controls:

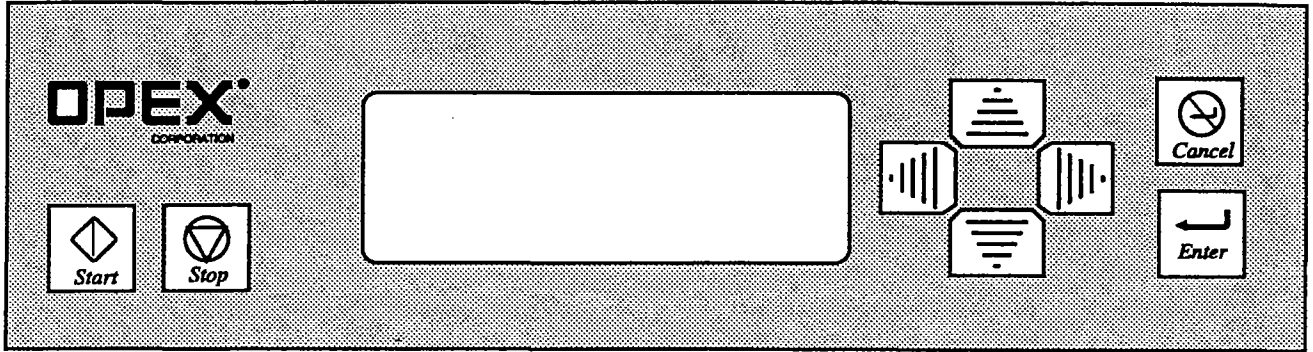

Make sure that the machine is plugged in and the mail is properly loaded. Press the ON key. The OPEX logo should appear for a few seconds, after which you should see a copyright screen indicating you are using a Model 50 equipped with the PCC.

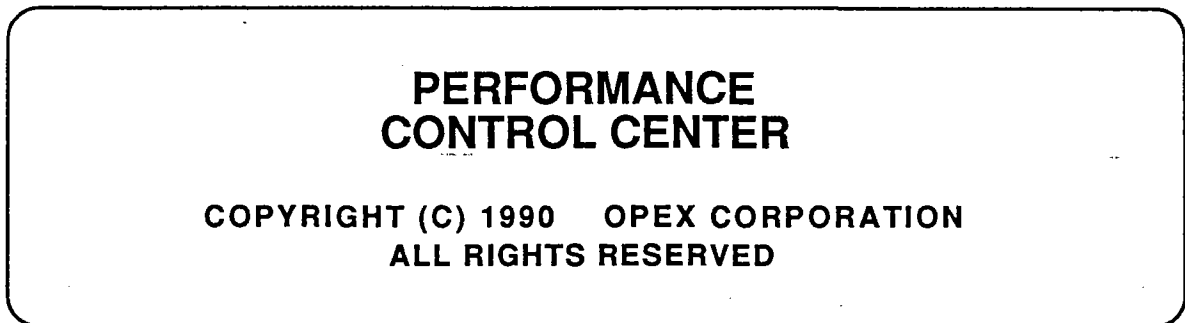

If these messages do not appear, check the wall plug. If you still don't see a display, you may need to adjust the screen contrast. Press the OFF key so that the machine is idle. Press the LEFT ARROW key, which should cause the OPEX logo to appear. If the OPEX logo is not visible, press the UP ARROW key (and continue to hold) until the display darkens and is readable. The UP ARROW and DOWN ARROW keys may be used to adjust screen darkness depending upon your preference.

Once you have done this, power up the machine as described above. If after doing these things you continue to be without a display, contact your service technician.

After the machine has been powered up and the contrast has been adjusted, the "Operator Main Menu" screen will appear:

MONDAY, JUNE 22, 1993 1:30 PM

OPERATOR: BOB
JOB: WHITE MAIL

SELECT OPERATOR **SELECT JOB**

As shown above, the current operator's name and the current job are displayed. If you wish to change the operator's name or run a different job, move the shadow highlight (using the right-hand arrow keys) to the desired change, either "Select Operator" or "Select Job".

If you wish to select a new operator's name choose "Select Operator". Press the ENTER key. The following screen will appear:

SELECT OPERATOR

BOB	JANE	3
4	5	6
7	8	9
10	11	12
13	14	SUPERVISOR

A list of 14 operators, as shown above, will be displayed along with a space marked "Supervisor". The current operator's name will be highlighted. Use the arrow keys to move the shadow highlight to the desired operator's name and press the ENTER key. The "Supervisor" function will be discussed later. After the new operator is selected, the "Operator Main Menu" screen will again be displayed, reflecting the change.

If you wish to select a new job, choose "Select Job". Press the ENTER key. The following screen will appear:

SELECT JOB		
JOB NAME	JOB NAME	3
4	5	6
7	8	9
10	11	2
13	14	15

A list of 15 jobs (see above) will be displayed. The shadow highlight will be on the current job. Use the arrow keys to select the proper job and push the ENTER key. If you don't want to select a job, press the CANCEL key.

After a new job is selected, a screen entitled "Adjust Settings" will be displayed and will look like this:

ADJUST SETTINGS		
JOB NAME:		
WHEN READY PUSH CYCLE BUTTON		
CUTTER HEIGHT	LEFT STRIP HEIGHT LOCAT	RIGHT STRIP HEIGHT LOCAT
5	6 7	6 7

Very Important: Before you run the selected job, adjust the cutter height and the stripper location(s) to match the settings on the screen. Look at the cutter and stripper. Make sure they correspond to the settings indicated. Different jobs will have different settings. A supervisor has chosen the setting for each job to make sure that your Model 50 operates as close to peak performance as possible.

If you forget to change the cutter and stripper settings when you change jobs, your Model 50 may not run the new job well.

To set the top cutter height, rotate the cutter knob **clockwise** to move the cutter **up**. Rotate the cutter **counter clockwise** to move the cutter **down**.

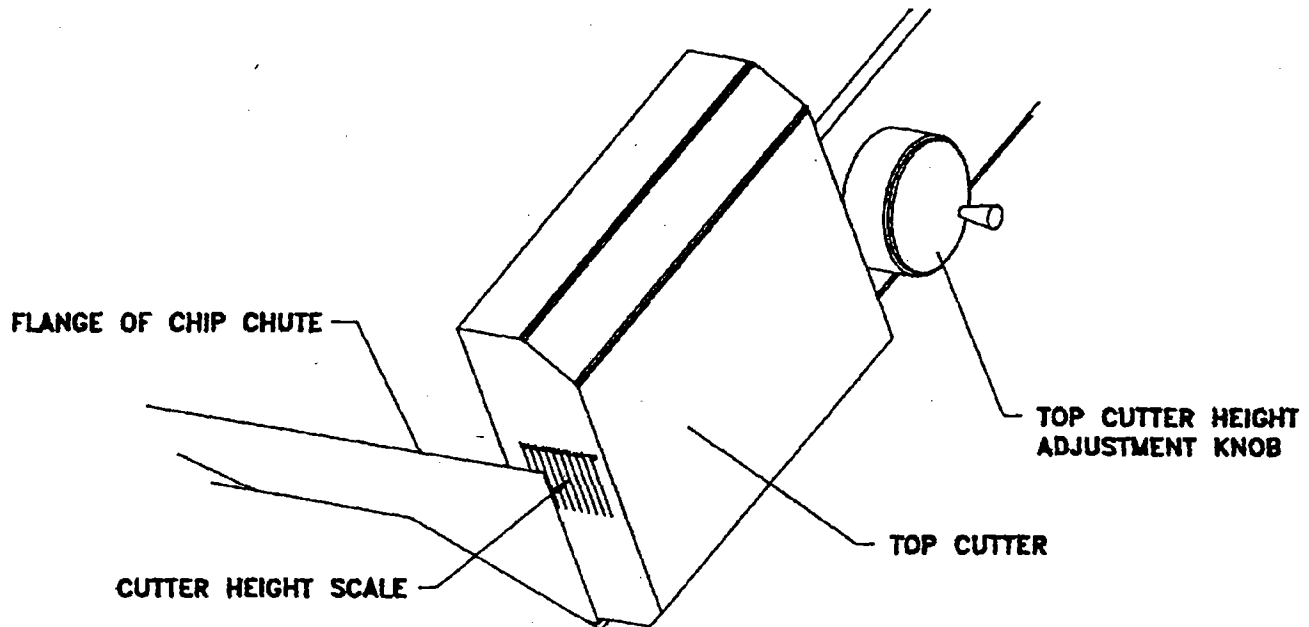

Illustration E. Top Cutter

The Cutter Height Scale will guide you in setting the height of the cutter. Make sure the Top Cutter is set to the height indicated on the "Adjust Settings" screen. If the knob does not rotate easily, do not force it. You may damage the top cutter.

Using the numbers on the stripper tab and stripper bar, (See Illustration "D") make the necessary adjustments by moving the stripper bar and stripper tab to the positions indicated on the "Adjust Settings" screen. Now you are ready to begin opening and extracting mail.

Processing Envelopes

(Please note: This Section assumes the envelopes are being processed utilizing the Content Activation Mode. Other modes do not require the use of the "Push to Cycle" button to move the envelope down the track from the extract station. For more information regarding this and all of the processing modes, see the Supervisor Section of the Manual).

Having selected the proper operator and job (which should now be displayed in front of you on the PCC), and having made the "Adjust Settings" screen adjustments, you are ready to begin the process of extraction.

CHOOSING THE FIRST ENVELOPE FOR OPENING AND EXTRACTING IS THE MOST CRITICAL PART OF THIS PROCESS.

The first envelope you choose to come off of the feed tray must be a good representative of the envelopes to follow. *It must not be an odd envelope.* It should not be covered with additional stamps (Christmas Seals, Easter Seals, etc.) nor should it contain additional inks or dyes (excessive pen marks on envelope, marker, writing, etc.). Here's why:

The first envelope must be fairly "clean" so that the machine "reads" what an empty envelope will look like. The OPEX Model 50 RED needs to be "taught" the difference between full and empty envelopes. If your first envelope is damaged or not typical of the rest, the machine may not "read" subsequent envelopes properly and an important document could be lost.

After you have chosen a good first envelope and placed it in the feed tray, press the "Push to Cycle" button to start the machine:

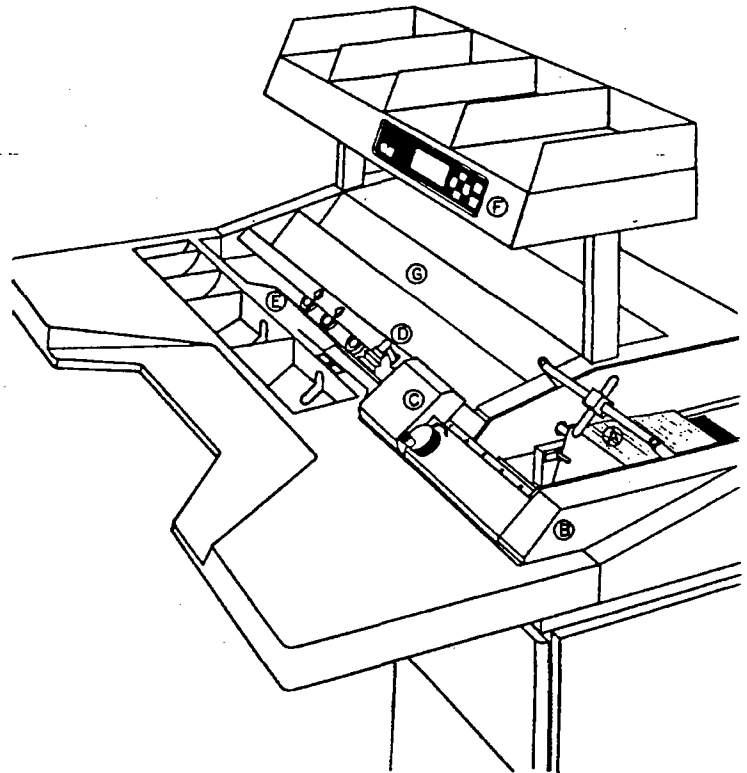

Illustration F. Extract / Candler Cycle

At this point, the machine will attempt to pick up the first envelope and move it through the side and top cutting stages for processing. If the machine cannot pick up an envelope in a few tries, it will shut itself off. If this happens, check to be sure the mail is loaded properly. Refer back to page 5 of this manual if you are not sure about proper loading. Make sure that the first envelope is sitting properly in the transport track.

The side and top of the envelope will be cut, depending on your particular job, and the envelope should move in front of you in the extract position. Here, the envelope will be held open by suction cups. Extract all of the contents. **Make sure the envelope is completely empty**, then press the Push-to-Cycle button. Machine sensor readings will be remembered by the machine and used to control future cycles. When the "Push to Cycle" button is pushed, the envelope will move to a second sensor, the candler, which determines what an empty envelope looks like. The machine will now cycle automatically as you remove envelope contents.

It is extremely important that you perform this operation properly. If you have chosen a bad first envelope, or if it doesn't open correctly, or if you accidentally pull the envelope out of the track, press the CANCEL key. Start over and repeat these procedures. Above all, verify that you have in fact removed all contents from the envelope before proceeding.

As you run the envelopes, it is possible that you will accidentally leave an item in the envelope. If the Candler option is activated, the machine will catch this mistake for you. If something remains in the envelope as it travels down the track to the Candling station, the "Remove Envelope—Check For Contents" red light will illuminate. (See Illustration F). When this happens, remove the envelope by hand, inspecting it to make sure all contents have been removed. Discard the empty envelope and resume operation.

If the Candler light comes on repeatedly, the first envelope was probably not run correctly. To solve this problem, turn the machine off. Clear the track of all envelopes and start over, using a new sample envelope.

While processing mail, you will see a graph displayed on the PCC. The graph screen display monitors your performance and alerts you to problems by presenting various *error* messages. Normally, the graph will look like this:

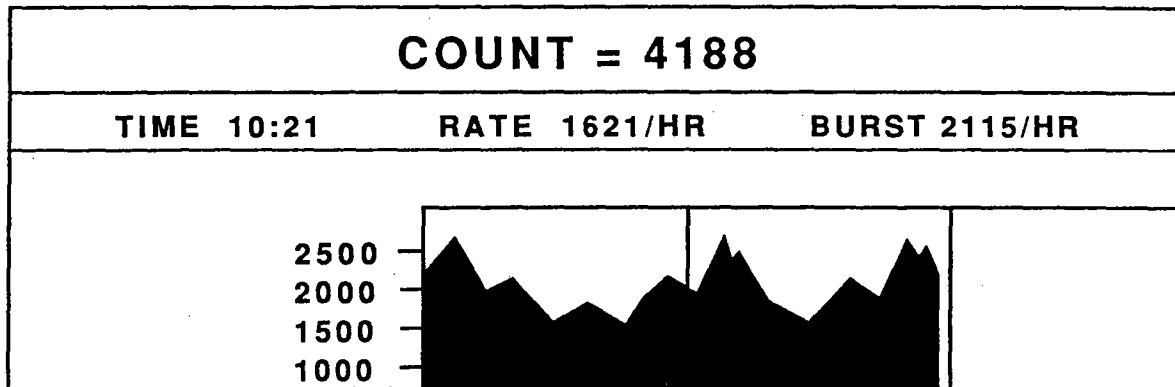

- Count:** - Number of Pieces Processed.
- Job Run Time:** Number of Hours and Minutes the Job has been Active.
- Rate:** Number of Pieces Processed divided by the Job Run Time.
- Burst:** Shows Operator's Peak Rate over a 6-Minute Span.
(Updated every Minute)

Envelope processing performance is updated each minute on this display. Three 1-hour periods of time are displayed and updated every hour. The horizontal line running across the screen indicates a pre-selected target rate. The target rate may be changed by the supervisor. In order for the count to record one processed envelope, the envelope must be properly picked up, opened and fed into the transport area.

If a jam occurs on your machine, the jam error screen will be displayed, followed by the run-time graph screen. These two screens will alternate until the machine is restarted by pushing the "Push to Cycle" button.

If your Model 50 RED has PCC capability, it may be made to run in a non-PCC mode by pressing the OFF key and then the ENTER key. This capability may prove to be a useful and faster tool for changing job parameters since you do not have to enter the Supervisor mode to make these adjustments.

NON-PCC OPERATION

If your machine is not outfitted with the Performance Control Center (PCC), there are two options available for making machine changes. All of the other information contained in the previous PCC section applies. The screen will look like this:

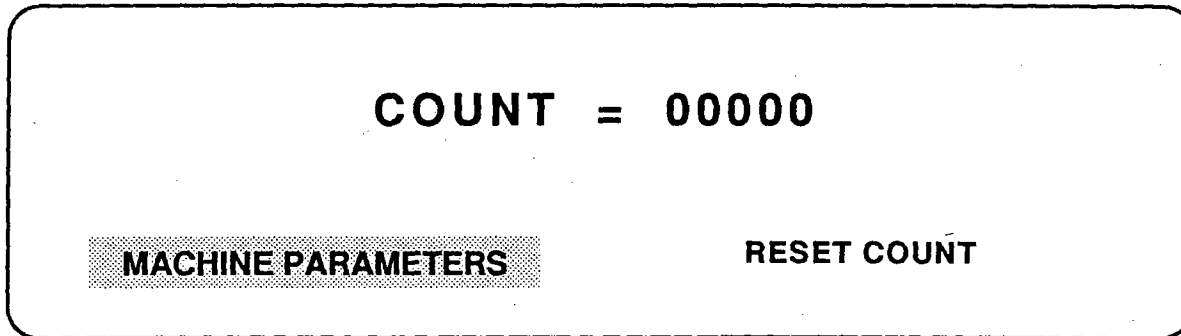

You may select either option by using the arrow keys to move the shadow highlight to the desired option. Choose the "Reset Count" feature by pushing the RIGHT ARROW key and then pressing ENTER. This will put the count back to "0" and allow you to start over. In order for the count to record one processed envelope, the envelope must be properly picked up, opened and fed into the transport area. You may select the "Machine Parameters" option by using the LEFT ARROW key. Then press the ENTER key. This produces the "Select Job Option" menu:

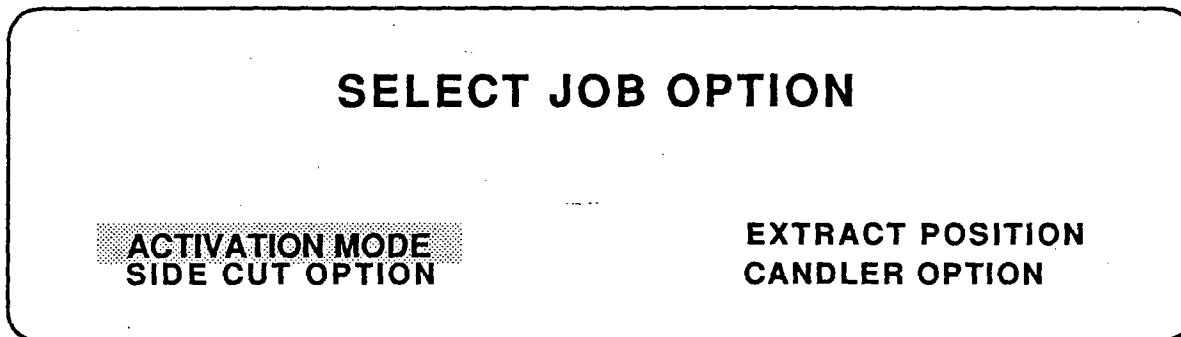

Using the appropriate arrow keys, any one of the four job parameters may be selected and changed. For further information regarding these job parameters, please refer to the Supervisor Section of this Manual.

As with PCC-equipped machines, if a jam occurs somewhere, the jam number and type will be briefly displayed. The screen will alternate between showing the machine count and the error message until the jam is cleared and the machine is restarted with the "Push to Cycle" button. Any job may be ended at any time by pushing CANCEL.

OPERATOR PREVENTIVE MAINTENANCE AND CLEANING

It is important that you keep your machine cleaned and in good working order. This will prolong the overall life of the machine and result in longer periods of "up" time.

Failure to perform daily cleaning tasks may result in the voiding of your service contract. Therefore, it is vitally important that you perform the following tasks at least once per day:

1. Dust the exterior of the machine. Accumulations of dirt can cover sensors, keeping them from doing their job. This will hinder machine performance. Any commercially available cleaning solution may be used to clean the shelves and sides.
2. Remove any chips of paper jammed in either of the cutters.
3. Empty the large trash receptacle on the left of the machine.
4. Empty the top cutter chip bucket located under the center of the machine.
5. Empty the side cutter chip box located under the side cutter.

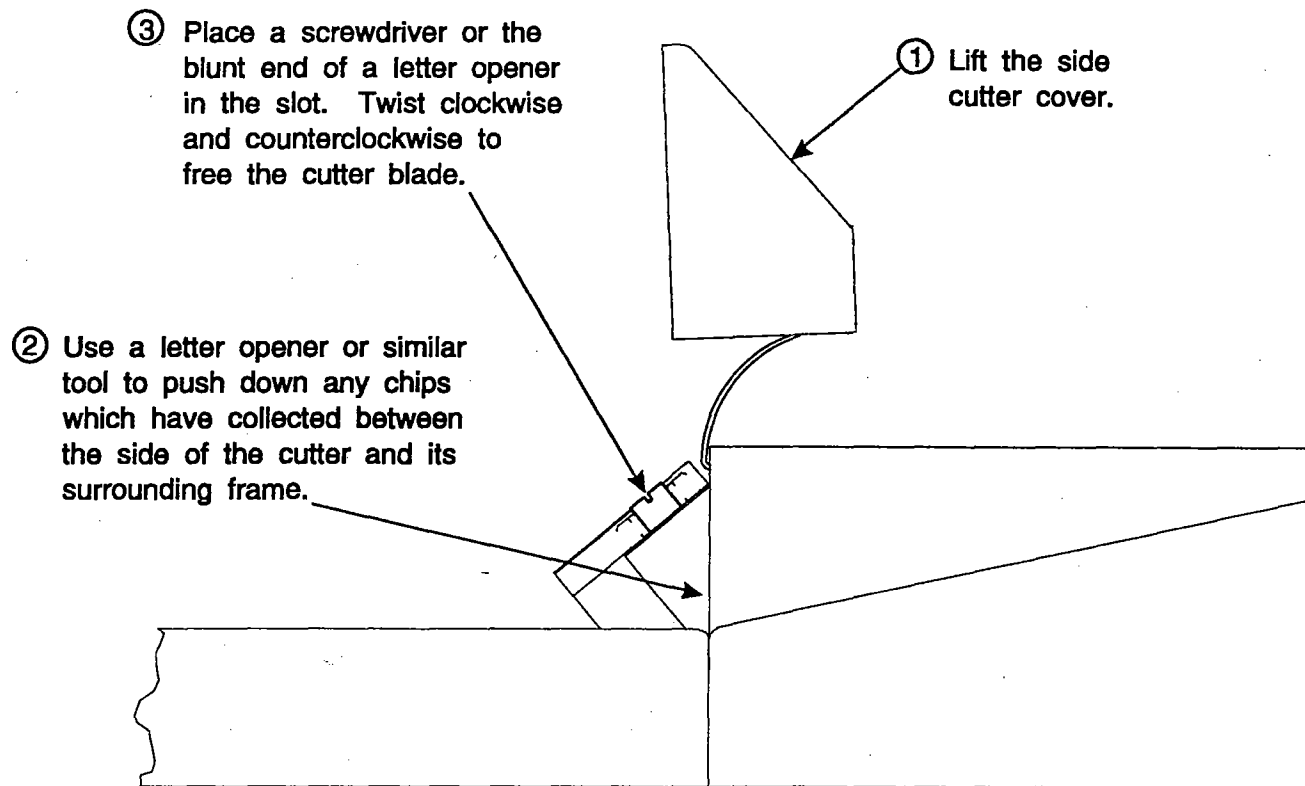

Illustration G. Clearing the Side Cutter

The side cutter opens the side of the envelope by cutting a small chip of paper from it. These chips fall down a chute into a trash box. Since the box is out of sight, operators sometimes forget that it is there, and allow it to fill up. The paper chips will "haystack," building up to the point where new chips can no longer fall to the trash. Instead they build up in and around the side cutter, causing it to jam.

The first indication of this will be an envelope which is cut only on the top. If this happens, lift the cover of the side cutter as shown above, and clear the paper chips. Empty the side cutter chip box. If the sidecutter is jammed, follow the instructions above to clear it.

TROUBLESHOOTING

Your OPEX Model 50 Rapid Extraction Desk is equipped to diagnose many of its own problems. When a problem occurs in the mail opening or extraction process, an error message will be displayed.

The various error messages are listed below. Possible solutions for resolving these errors are listed afterward. If following these suggestions does not produce a satisfactory result, contact your authorized OPEX Service Representative.

Error Name	Cause	Clearance Procedure
Miscellaneous Error	This error occurs infrequently and may be caused by a number	Restart the machine by using the 'Push to Cycle' button.
Feed Cycle Time-Out	This error occurs when an envelope jams during feed and prevents the feed motor from completing its cycle.	Look for a jam in the feed area and clear it.
Feed Retry Error	This error occurs when the machine is unable to feed an envelope after repeatedly trying to do so.	Look for a jam in the feed area and clear it.
Side Cut Blocked Time-Out Error	This error is caused by an envelope not properly moving out of the side transport area (see Illustration A).	Inspect the side transport area and remove any jammed mail. Inspect the side transport and side cutter areas to see if cut pieces or foreign material from previous envelopes are blocking the cutter (see illustration H).
Top Cutter Sensor Blocked Error	This error is usually caused by an envelope jam in the top cutter.	Inspect the top cutter and clear any jams. See if cut pieces or foreign material from previous envelopes are blocking the sensor.

Error Name	Cause	Clearance Procedure
Top Cutter Sensor Time-Out Error	This error is usually caused by an envelope jam in the feed area.	Inspect the feed area and clear any jams.
Top Cutter Blocked Time-Out Error	This error is usually caused by an envelope jam in the top cutter.	Inspect the top cutter and clear any jams. See if cut pieces or foreign material from previous envelopes are blocking the cutter.
Extract Cycle Time-Out Error	This error is usually caused by an envelope preventing the extract heads from operating properly.	Clear any mail jammed in the main transport and extract areas.
Extract Not Cleared Error	This error is caused by an envelope not leaving the extract area.	Clear any mail jammed in the main transport and extract areas.
Extract Not Blocked Error	This error occurs when an envelope does not arrive in the extract area at the proper time.	Clear any mail jammed in the main transport and extract areas.

If you are unable to clear the errors listed above by following the simple directions listed, contact OPEX for service. **Do not attempt to disassemble the machine or perform any service other than that indicated.** Doing so can be dangerous. It may cause additional machine damage or may void your service warranty or contract.

ACCESSORIES

Performance Control Center (PCC)

Desks are equipped with this function by OPEX and arrive at your facility ready to operate. For operation of the PCC functions, please refer to the Operator and Supervisor portions of this manual. If your machine is not equipped with the PCC, refer to page 16 of this manual.

The OPEX Network Solution™

Your OPEX Model 50 REDs may be linked together on a LAN (local area network). This is called networking. Networking allows a supervisor to gather statistics from a PC linked to your Model 50, and may also allow the supervisor to change job names, operator names, job parameters and machine parameters from the PC without interrupting you as you work.

The Ergonomic Desk Chair

As noted earlier in this Manual, we strongly recommended that the proper chair be used when operating the Model 50 RED. The right chair will help you maintain proper posture, avoiding potential aches and muscle fatigue.

OPEX offers an optional desk chair specifically designed for this purpose. Its operation, along with some stress troubleshooting guidelines, are detailed on the following pages.

MANAGING STRESS, PAIN & DISCOMFORT

The following ergonomic chair information will assist you in attaining the most comfortable position for your particular build and size.

For the most part, pain and discomfort in a particular area of the body can be eliminated by following the instructions for adjusting your chair or workstation. For troubleshooting specific problems, identify the condition and probable cause of your discomfort on the following pages.

Condition	Probable Cause	How to Correct
<p>Neck tension or tightness in the upper back and shoulders.</p>	<p>Head is too far forward while operating the machine.</p> <p>Hands and arm are not supported</p> <p>Head is too far back.</p> <p>Arms are held too high relative to your body as you work.</p> <p>Arms are doing too much manual activity or are extended too far forward.</p>	<p>Elevate the work surface and materials to keep the head and torso relationship more vertical.</p> <p>Use armrest, wrist rest, palm rest, or work surface to counter-balance the weight of the hands and arms.</p> <p>Tilt the seat and backrest forward so as to keep the head and torso relationship more vertical.</p> <p>Lower the work surface so that the weight of the arms is all that is being supported.</p> <p>Lower the work surface or use leverage and weight to gain an advantage.</p> <p>Keep work closer to your body.</p>

Hints for Continued Comfort:

During the day, adjust your chair support postures other than neutral posture. Maximum benefit will be experienced at neutral posture, but adjusting to other postures temporarily will promote circulation and muscle tendon ligament stretching.

While you are working, support your arms on your work surface. This will take some of the pressure off of your neck and shoulders to give you a more balanced feeling in the chair.

Loose fitting clothing of natural fibers, such as wool and cotton, is recommended because it will help reduce heat build-up in the chair and allow more freedom of movement.

Condition	Probable Cause	How to Correct
Lower back pain or discomfort	<p>Lower back is not being firmly supported.</p> <p>Major thigh muscle is pulling on the spine because feet are dangling or are unsupported.</p> <p>Increased disc pressure because of poor posture.</p>	<p>Bring the backrest in closer by tilting the seat forward. The backrest should be placed just slightly above the pelvis and should provide support to the lower back.</p> <p>Lower the chair or use a foot rest so that your feet support only the weight of the feet and lower legs.</p> <p>Open up the torso-thigh angle Sit up straight.</p>
Buttocks or crotch discomfort	Too much pressure on the pubic area caused by sitting too far forward in the seat pan and making contact with the saddle portion of the seat pan.	Sit deeper in the chair. You may find it helpful to adjust the tilt angle of the backrest, or to tilt the seat pan back. Try looser fitting clothing.
Thigh discomfort	Too much pressure on the thigh because the chair is too high or your legs are dangling.	Lower the chair height so that your feet support the feet and lower legs only.
Lower leg discomfort	<p>Too much pressure on the soft tissue area behind the knee can restrict circulation to your lower legs and your feet. It also can put pressure on the nerves to your lower legs and feet.</p> <p>Infrequent posture changes of the feet and lower legs.</p>	<p>Sit farther forward in the seat and adjust the backrest accordingly farther forward.</p> <p>Utilize a well-designed footrest to promote movement and frequent posture changes.</p>

CAUTION: DO NOT LET ANYONE PLACE THEIR HAND UNDER THE SEAT PAN WHILE YOU ARE ADJUSTING THE CHAIR. Guards have been added to prevent access to the control assembly mechanism where pinch points exist. Do not remove the guards because injury can result from pinch points for some adjustments.

*** BE SAFE! KEEP YOUR HANDS ON THE HANDLES ***

THE PRINTER OPTION

The printer package allows you the advantage of printing hard copy statistics. The printer is available in both permanent and portable versions. The permanent printer, located in the top shelf of the machine, is recommended as it saves printing time, reduces possible printer damage and maximizes the efficiency of each work station.

Loading printer paper

To load printer paper into the permanent printer, locate the small thumbscrew under the top shelf of the machine at the front of the printer. Put your hand beneath the printer unit so that it won't drop down after the screw is unfastened. Unfasten the thumbscrew by turning it slowly counterclockwise.

When the screw is fully loosened, the printer will drop down. Before removing the old paper roll, note how the remaining paper is routed through the printer. Remove the old roll and take the metal shaft from the center of the roll. Obtain a new roll of printer paper (paper may be ordered through your OPEX Service Representative), place the metal shaft through the center of the roll and place the roll into the printer. Enter the supervisor mode, select "View Statistics" and then select "Print Data". Place the lead edge of the paper between the black feed rollers on the printer and press the "Enter" button. The printer will then begin to print and will automatically pull the paper through the feed rollers. When the print cycle has stopped, slowly swing the printer up towards its operating position making sure that the end of the paper feeds through the slot in the front of the top shelf. Once the printer is all of the way up, tighten the thumbscrew.

The portable printer utilizes an "On/Off" switch and a paper feed switch labeled "PF". The printer must be turned "on" to print the reports listed under the printer function menu described elsewhere in this manual. The portable printer is battery operated. When not being used, the printer should be kept plugged into the power supply provided.

To load printer paper, remove the old roll from the back of the printer. Load the new paper in the direction indicated on the roll and snap the new roll into place. To advance the paper in the printer, push the "PF" switch on the printer.

THE OPEX NETWORK SOLUTION™

The OPEX Network Solution™ is an optional package which allows your supervisor to monitor productivity of all Model 50s from a remote PC. Job setup and modification can also be performed from a remote PC.

This Windows™ based program provides consolidation of data and allows reports to be viewed and printed according to your company's particular format. Data can be imported into virtually any spreadsheet program and manipulated for custom reports. Some capabilities require a Novell Fileserver and LAN. Ask your OPEX Sales Engineer for particulars.

SPECIFICATIONS

Power Consumption:

U. S.:

Nominal Input = 115 VAC / 60 Cycles

Maximum Input Voltage = 122 VAC

Minimum Input Voltage = 104 VAC

Average Power Consumption = 650 Watts

Europe:

Nominal Input = 220 - 240 VAC / 50 Cycles

Maximum Input Voltage = 254 VAC

Minimum Input Voltage = 198 VAC

Average Power Consumption = 650 Watts

Heat Generation:

Average Heat Generated = 2200 BTU/Hr.

SERVICE ACCESS AREA

The diagram below details the area around the machine which **must be available for access** to a service technician. Failure to observe these area requirements may void any applicable service contract. OPEX is under no obligation to service a machine not in conformity to these spatial requirements:

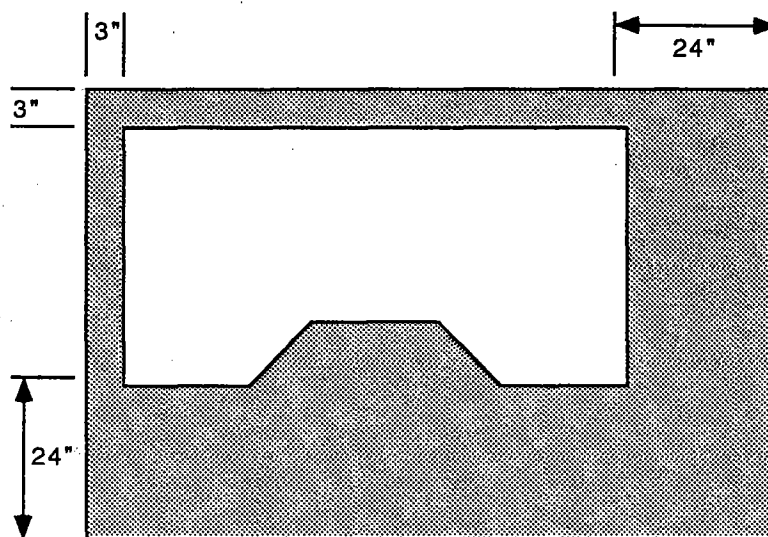

Gray area indicates open space.

SAFETY CERTIFICATIONS

Product safety certification is a requirement for machines placed in the workplace in both the United States and Canada. In the US, OSHA regulations Part 1910, Subpart S, require such machines to have a listing by a "Nationally Recognized Testing Laboratory" (NRTL). Dash, Strauss & Goodhue, Inc. (DS&G) is one of five NRTLs certified by OSHA to perform such testing. Compliance is demonstrated by testing to accepted industry standards.

The OPEX Model 50 Rapid Extraction Desk has been tested to US Standard UL1950, the stringent new safety standard for Information Technology Equipment. DS&G has evaluated the Model 50 and has certified that it may bear the listing mark.

Canadian law requires that such products meet Canadian Standards Association (CSA) C22.2. Under the US - Canadian Free Trade Agreement (FTA), both the US and Canada must "provide for the recognition of the accreditation systems...of the other party." DS&G, an NRTL, falls under these provisions. The Certification Mark is offered as evidence of conformity with the Canadian Electrical Code and the standard CSA C22.2 No. 220.

DS&G has in addition performed an inspection and declared that the Model 50 machines manufactured for export to the European Community can be certified to be in compliance with EC Product Safety law according to the Low Voltage Directive (73/23/EEC). A Declaration of Conformity which declares this compliance according to the standard IEC 950 accompanies each machine shipped to the European Community.

ELECTROMAGNETIC INTERFERENCE (EMI) CERTIFICATIONS

Canada

This digital apparatus does not exceed the Class A limits for radio noise emissions from digital apparatus set out in the Radio Interference Regulations of the Canadian Department of Communications.

Le present appareil numerique n'emet pas de bruits radioelectriques depassant les limites applicables aux appareils numeriques de la Class A prescrites dans le Reglement sur le brouillage radioelectrique edicte par le ministere des Communications du Canada.

Germany

BESCHEINIGUNG DES HERSTELLERS/IMPORTEURS

Hiermit wird bescheinigt, dass das OPEX Model 50 in Übereinstimmung mit den Bestimmungen der Vfg 1046/1984 funk-entstort ist.

Der Deutschen Bundespost wurde das Inverkehrbringen dieses Gerates angezeigt und die Berechtigung zur Überprüfung der Serie auf Einhaltung der Bestimmungen eingeräumt.

CERTIFICATE BY MANUFACTURER/IMPORTER

This is to certify that the OPEX Model 50 is shielded against radio interference in accordance with the provisions of Vfg 1046/1984.

The German Postal Services have been advised that this device is being put on the market and that they have been given the right to inspect the series for compliance with the regulations.

United States

Note: This equipment has been tested and found to comply with the limits for a Class A digital device, pursuant to Part 15 of the FCC rules. These limits are designed to provide reasonable protection against harmful interference when the equipment is operated in a commercial environment. This equipment generates, uses and can radiate radio frequency energy and, if not installed and used in accordance with the instruction manual, may cause harmful interference to radio communications. Operation of this equipment in a residential area is likely to cause harmful interference in which case the user will be required to correct the interference at his own expense.

Warning: Changes or modifications to this unit not expressly approved by the party responsible for compliance could void the users authority to operate the equipment.

DECLARATION OF CONFORMITY

Application of Council Directive(s) 73 / 23 / EEC

Standard(s) to which Conformity is Declared IEC 950

Manufacturer's Name Opex Corporation

Manufacturer's Address 305 Commerce Drive

Moorestown, NJ 08057

Importer's Name

Importer's Address

Type of Equipment Information Technology Equipment

Model No., 50

Serial No.,

Year of Manufacture

I, the undersigned, hereby declare that the equipment specified above conforms to the above Directive(s) and Standard(s).

Place Moorestown New Jersey

(Signature)

Date May 21, 1991

Albert Franklin Stevens

(Full name)

President

(Position)

notes

OPEX Corporation
305 Commerce Drive
Moorestown, NJ 08057-4234